



Global Jet Sales
Corporate Trading, Inc.

111 Second Ave. NE, Suite 103
St. Petersburg, FL 33701
727.864.9443 ~ Fax 727.864.9448

3775 Flight Avenue, Suite 204
Redding, CA 96002
530.226.3399 ~ Fax 530.226.3398

www.JetSearch.com ~ sales@JetSearch.com

1980 Challenger 600

s/n 1006

PAINT 03/2010
MSPG ~ CAMP
EFIS ~ PART 135
CHAL 604 INTERIOR
60 MTH GEAR C/W 7/07



Contact: Garrett Burke
sales@jetsearch.com



Global Jet Sales

Corporate Trading, Inc.

sales@JetSearch.com
111 2nd Ave NE Suite 103
Saint Petersburg FL 33701
727-864-9443

3775 Flight Avenue Suite 204
Redding CA 96002
530-226-3399
www.JetSearch.com

1980 CHAL 600 S/N: 1006

\$MAKE OFFER

AirFrame *CAMP*

7735 Hours since New

4722 Landings

Engines

LYC ALF502 -L2C

MSPG

Engine 1

8251 SNEW

1164 SMOH

Engine 2

8481 SNEW

703 SMOH

Auxiliary Power Unit

ALLIED SIGNAL

5095 Total Time

1245 SOH

Avionics

5 Tube HONEYWELL FZ-500 EFIS
2 COLLINS VHF-22D COMMS
2 COLLINS VIR-32 NAV'S
2 COLLINS ADF-60A ADF
2 COLLINS DME-42 DME
2 HONEYWELL MST-67A TDR
1 HONEYWELL PRIMUS 800 RADAR
2 UNIVERSAL UNS-1D FMS
1 UNIVERSAL UNS-1D GPS
1 LITTON LTN-91 INERTIAL
2 COLLINS HF-671U W/SELCAL HF

HONEYWELL ACAS 2 TCAS
ARTEX 406 MHZ ELT
MAGNASTAR C2000 AIRPHONE
COMP WARN
UNIVERSAL TAWS GPWS
SUNDSTRAND AV557C CVR
LOCKHEED 319C FLT RECORDER
HONEYWELL SP-600 AUTOPILOT

Special Features

RVSM/RNP-5	120 MO GEAR REST 8/01	100 HR C/W 3/10
8.33 SPACING	MLG & NSE OH C/W 5/02	24 MO C/W 1/12
WINGLETS	36 MO/4000 LNG C/W 10/06	48 MO C/W 1/12
STEER BY WIRE	60 MO W/GEAR INS C/W 7/07	12 MO C/W 1/12
PART 91/135	5 BRAKES 7/07	300/600 CW 1/11
DAVTRON CLOCK	WEIGHT & BALANCE 7/07	72 MO C/W 1/12
4-120V OUTLETS	RADOME OVERHAUL	GEAR 120 MO DUE 7/12
SPERRY VA-100	AD'S & SB'S C/W	1200/1800/2400 AF CW 3/08
SPERRY MHRS		400/2400 APU C/W 2/08

Exterior 03/2010

OVERALL WHITE W/RED & BLACK STRIPES.

Interior 08/2002

ELEVEN PLACE FIREBLOCKED 604 INTERIOR W/FWD DBL CLUB,AFT CONFERENCE GROUP OPPOSITE THREE PLACE DIVAN. TAN LEATHER UPHOLSTERY, TAN SIDEWALLS, HEADLINER & CARPET. HIGH GLOSS AMERICAN RED WALNUT WOODWORK W/GOLD PLATING. FWD S GALLEY W/ CONVECTION & MICROWAVE OVENS, DUAL HOT POTS FOR COFFEE/TEA. ENTERTAINMENT INCL AIRSHOW GENESYS, DUAL 15" FWD/AFT MONITORS & CD/DVD. LARGE AFT LAV. JUMPSEAT. WATER HEATERS FOR LAV/GALLEY. REFURBISHED INTERIOR 8/02 BY GULFSTREAM.

Weights

MTOGW: 41,250	RAMP: 41,400	ZFW: 28,500	LANDING: 36,000
BOW: 26,527	EMPTY: 24,807	FUEL WT: 10,900	FUEL CAP: 2,190



Global Jet Sales

Corporate Trading, Inc.

111 Second Ave. NE, Suite 103
St. Petersburg, FL 33701
727.864.9443 ~ Fax 727.864.9448

3775 Flight Avenue, Suite 204
Redding, CA 96002
530.226.3399 ~ Fax 530.226.3398

www.JetSearch.com ~ sales@JetSearch.com

Exterior



Cockpit



Global Jet Sales

Corporate Trading, Inc.

111 Second Ave. NE, Suite 103
St. Petersburg, FL 33701
727.864.9443 ~ Fax 727.864.9448

3775 Flight Avenue, Suite 204
Redding, CA 96002
530.226.3399 ~ Fax 530.226.3398

www.JetSearch.com ~ sales@JetSearch.com

**Interior
Fwd**



**Interior
Aft**



Global Jet Sales

Corporate Trading, Inc.

111 Second Ave. NE, Suite 103
St. Petersburg, FL 33701
727.864.9443 ~ Fax 727.864.9448

3775 Flight Avenue, Suite 204
Redding, CA 96002
530.226.3399 ~ Fax 530.226.3398

www.JetSearch.com ~ sales@JetSearch.com



Int Aft



Galley



ESTIMATED VARIABLE COSTS - Per Hour

CL 600

Fuel (1)	\$2,347.84
Fuel Additives	
Lubricants	

Maintenance Labor (2)	412.92
Parts Airframe/Eng/Avion (3)	577.69

Engine Restoration (4)	1,110.94
Thrust Reverser Allowance	
Propeller Allowance	
APU Allowance	96.25
Major Periodic Maintenance	

Misc Exp. - Landing/Parking	42.33
- Crew Expenses	268.65
- Supplies/Catering	141.75
- Carbon Offset (5)	
- Other	

Fractional Fuel Surcharge Cost/Hour + Tax
Fractional Cost/Hour + Tax

Total Variable Cost/Hour **\$4,998.37**

Cost per Nautical Mile \$12.37

Average Speed-Kts. (6) 600-nm trip 404.00

Cost data in this report is intended to be used as a benchmark

FOOTNOTES - Size of Operation: 1 - 2 Aircraft

Date: 3/29/2012

Currency: \$

Type of Operation: **Corporate**

1. Fuel Cost	6.67
Gallons/Hour Blk Fuel/Flt Time +15%	352
2. Maint. Labor Cost per Hour	93
Maint. Hours/Flight Hours	4.44
3. Incl. Engine Parts Cost	No
Engine Model	ALF 502L
Aircraft Model Year	1983
4. Overhaul Cost Source	Estimated
5. CO2 Cost Per Tonne	
6. Block Speed Source	Mftr Data



ANNUAL FIXED COSTS

CL 600

Crew salaries - Captain (7)	\$130,000
- Co Pilot	85,000
- Flt Attendant	84,000
- Flt Eng/Other	
- Benefits	89,700
Hangar - Typical	57,900
Insurance - Hull (8)	9,500
Single Limit Liability	16,500
<hr/>	
Recurrent Training	51,400
Aircraft Modernization (9)	75,000
Navigation Chart Service	17,802
Refurbishing (10)	87,885
Computer Mx. Program (11)	9,500
Weather Service (12)	700
Other Fixed Costs	
Mgmt Fee/Yr	
Total Fixed Cost/Year	\$714,887

Cost data in this report is intended to be used as a benchmark

FOOTNOTES - Size of Operation: 1 - 2 Aircraft

Date: 3/29/2012

Currency: \$

7. Crew Salary Source	10 NBAA
Number of Crew	3
8. Ins Hull Value/Frac Share Cost	1,900,000
Hull Insurance Rate (%)	0.50
9. Modernization	10 Yr Avg
10. Refurbish Labor Hrs/Seat	105
11. Comp. Mx Program Source	Typical
12. Weather Service Source	Typical



ANNUAL BUDGET

CL 600

Utilization - Nt. Miles	175,000
- Hours	433

Variable Cost	2,164,295
Fixed Cost	714,887
Total Cost (No Depreciation)	\$2,879,182
- Per Hour	6,649.00
- Per Nt. Mile	16.45
- Per Seat Nt. Mile	1.83

Total Cost (No Depreciation)	2,879,182
Book Depreciation (13)	190,000
Total Cost (Book Dep)	\$3,069,182
- Per Hour	7,088.00
- Per Nt. Mile	17.54
- Per Seat Nt. Mile	1.95

Total Cost (No Depreciation)	2,879,182
Market Depreciation (14)	76,000
Total Cost (Market Dep.)	\$2,955,182
- Per Hour	6,825.00
- Per Nt. Mile	16.89
- Per Seat Nt. Mile	1.88

Cost data in this report is intended to be used as a benchmark

Footnotes - Size of Operation: 1 - 2 Aircraft

Date: 3/29/2012

Currency: \$

13. Book Depreciation Rate 10% per yr

14. Market Depreciation Rate 4.00



GENERAL COMPARISON

CL 600

Cabin-Height (Ft.)	6.10
- Width	8.20
- Length	28.30
Cabin volume (Cu. Ft.)	1,035.00
Cabin Door Height (Ft.)	5.80
- Width	3.00
Baggage -Int. (Cu.Ft.)	115.00
- External	
Typical Crew/Pass Seating	3/9
Weight-Max Take-off (Lbs.)	41,250
- Maximum Landing	36,000
- Basic Operating	24,150
- Usable Fuel	14,640
Payload-Full Fuel (Lbs.)	2,610
- Maximum	6,850
Certified	Yes
IFR Certified	Yes
Price - New (Corporate)/1000	9,000
- Pre Owned Rng/1000	1,500/1,900
- Years Produced	1981 - 1983



PERFORMANCE COMPARISON

CL 600

Range-NBAA IFR Res (N.Mi.)	
Seats Full	2,800
Ferry Range - (Pilot(s) only, no pax)	2,880
Range-30 Min. Res (N.Mi.)	
Seats Full	
Ferry Range - (Pilot(s) only, no pax)	
Balanced Field Length (Ft.)	6,200
Landing Field Length - FAR 91	2,490
Landing Field Length - FAR 121	4,150
Landing Field Length - FAR 135	3,113
Rate Of Climb (Ft/Min)	
- One Engine Out	743
Cruise Speed-Max (KTAS)	
- Normal	458
- Long Range	401
Stall Speed (IAS)	
Ceiling-Service MTOW (Ft.)	39,000
- Certified	40,000
- Service OEI	23,900
- Hover IGE (Helicopter Only)	
- Hover OGE (Helicopter Only)	

EXTERIOR

Scale = 1:190

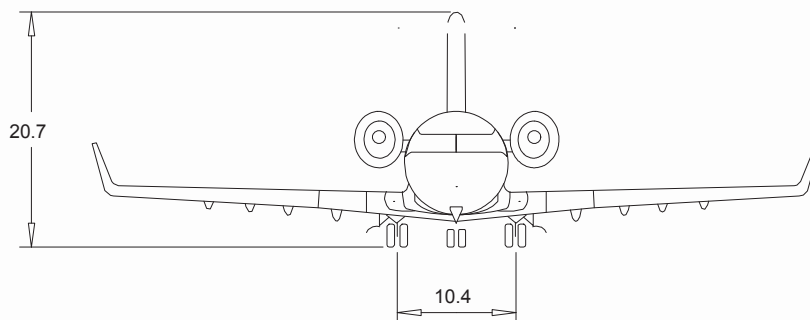
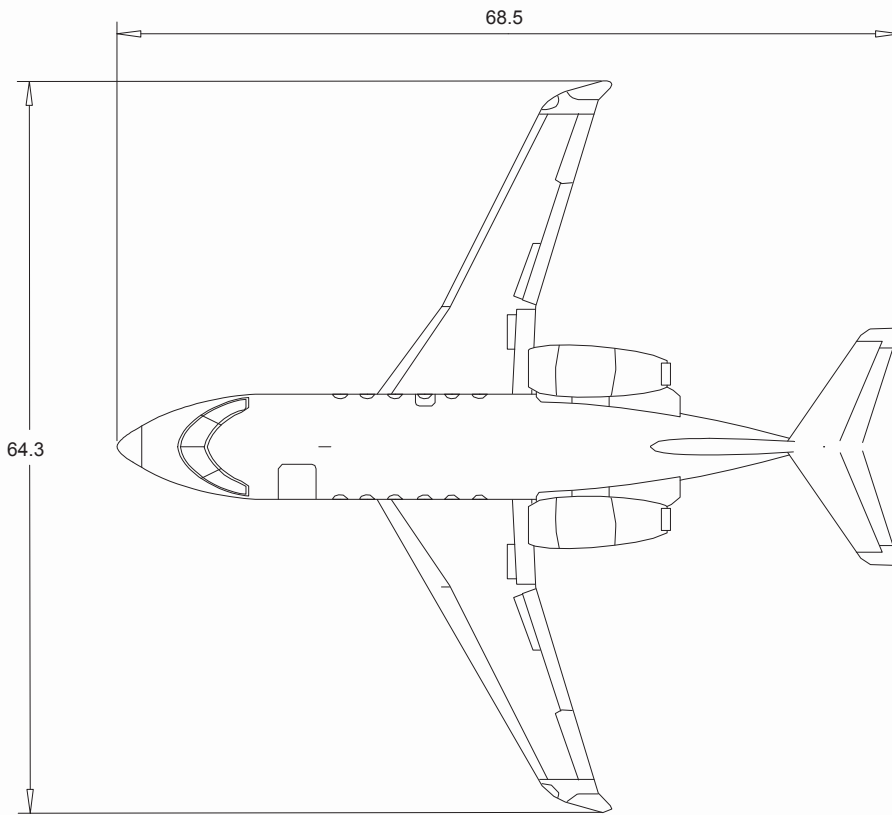
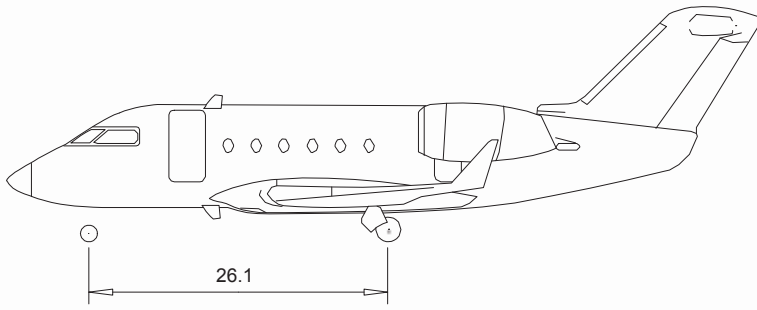

All dimensions are measured in Feet unless otherwise specified.

Challenger 600

Orleans, Massachusetts (508)255-5975

© 2006 Conklin & de Decker Associates, Inc.

INTERIOR

Orleans, Massachusetts (508)255-5975

© 2006 Conklin & de Decker Associates, Inc.

Scale = 1:40

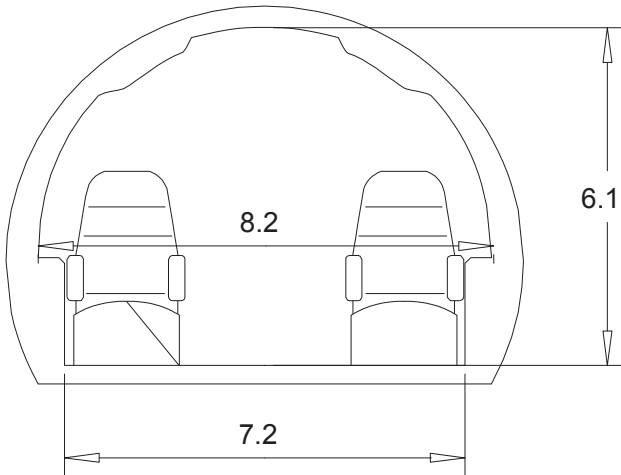

Challenger 600

Scale = 1:50

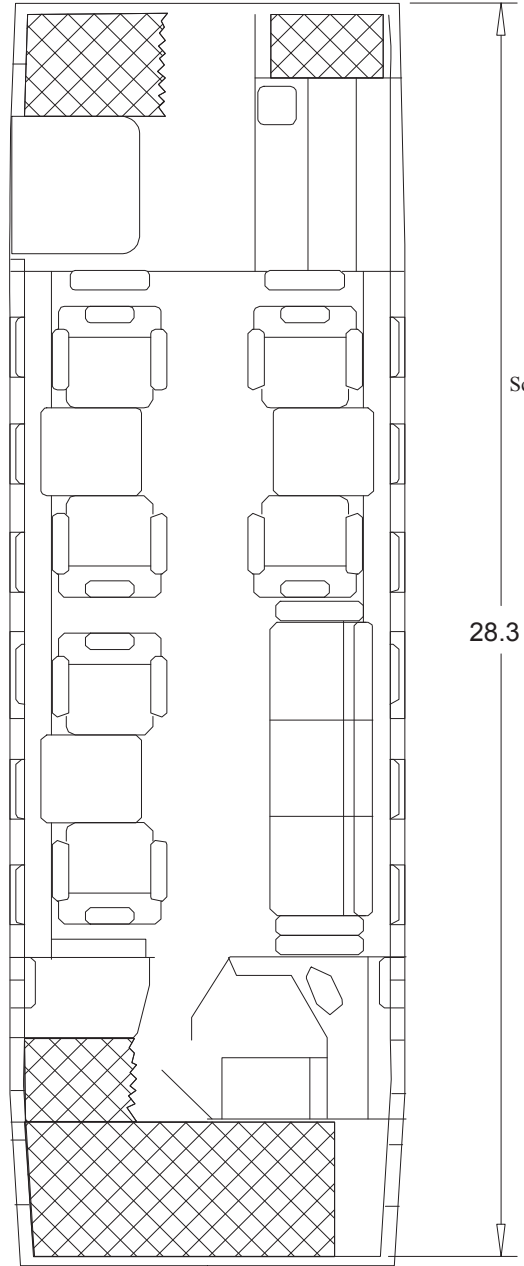

 - Baggage

All dimensions are measured in Feet unless otherwise specified.



Challenger 600

For over half a century, Canadair was Canada's leading aircraft manufacturer. Between its founding in 1944 and its 50th Anniversary, the company manufactured over 4,000 aircraft and many other products. Acquired by Bombardier Inc. in 1986, Canadair has since been absorbed into Bombardier Aerospace.

The Challenger 600 is the original model of the Challenger line of aircraft. It is equipped with Rolls-Royce ALF-502's that created a lot of noise and vibration in the cabin. It has a roomy 1,035 foot cabin with ample space for nine passengers.