



**Global Jet Sales**

Corporate Trading, Inc.

111 Second Ave. NE, Suite 103  
St. Petersburg, FL 33701  
727.864.9443 ~ Fax 727.864.9448

Additional Offices in:  
Redding, CA  
Warrenton, VA

[www.JetSearch.com](http://www.JetSearch.com) ~ [sales@JetSearch.com](mailto:sales@JetSearch.com)

# **2003 Falcon 2000 EX**

## **s/n 23**

**Low AFTT**  
**135 Certified**  
**Eng's On ESPG**  
**Sat/Com & HUD**  
**10 PAX (current config. 9)**



**Contact: Alexander Janas**  
**[sales@jetsearch.com](mailto:sales@jetsearch.com)**



# Global Jet Sales

Corporate Trading, Inc.

sales@JetSearch.com  
111 2nd Ave NE Suite 103  
Saint Petersburg FL 33701  
727-864-9443

3775 Flight Avenue Suite 204  
Redding CA 96002  
530-226-3399  
www.JetSearch.com

**2003 F-2000EX S/N: 23**

**\$MAKE OFFER**

**AirFrame** *CAMP*

3031 Hours since New  
1573 Landings

**Engines**

P&W 308C  
*Engine 1* 2857 SNEW  
*Engine 2* 2870 SNEW

*ESPG*

**Auxiliary Power Unit**

GARRETT GTCP-36-150

1592 Total Time

**Avionics**

4 Tube COLLINS PROLINE IV EFIS  
3 COLLINS VHF-422C COMMS  
2 COLLINS VIR-432 NAV'S  
2 COLLINS ADF-462 ADF  
2 COLLINS DME-442 DME  
2 TDR-94D MODE S W/ENH SURV TDR  
1 COLLINS RTA-858 RADAR  
2 COLLINS FMS-6100 FMS  
2 COLLINS GPS-4000A GPS  
2 HONEYWELL LASEREF IV INERTIAL  
2 COLLINS HF-9034 W/SELCAL HF

COLLINS TCAS-II TCAS  
HONEYWELL 700RB AFIS  
MAGNASTAR 2CHANNEL SAT/COM  
FLIGHT DYNAMICS HGS-2850 HUD  
ELTA 406-AF ELT  
HONEYWELL MK V EGPWS  
HONEYWELL AR-30 CVR  
HONEYWELL AR-256(PARA 88) FLT RECORDER  
COLLINS APS-4000 AUTOPILOT

**Special Features**

FAR 135 CERTIFIED  
MNSP / NAT  
RVSM/8.33/FM IMMUNITY  
COLLINS ALT-55B RA  
MOD CMLPT FOR 2ND RA  
CAPPS  
WX-1000E STORMSCOPE  
THERAPEUTIC O2  
COLLINS DAU-4000

COLLINS AHC-850E AHRS  
DUAL COLLINS ADC-850C  
EROS ANTI-SMOKE GOGGLES  
EROS 02 MASKS  
SECURAPLANE 4-CAM SYSTEM  
2 HANDSETS IN CABIN  
MEGGITT STDBY INDICATORS  
DUAL DAVTRON CLOCKS  
AFIS SKYPRINTER

1A/2A/1B/2B C/W 3/2012  
1A+/2A+/4A+ C/W 3/2012  
3A/3A+ INSP C/W 8/2011  
BASIC 60D/200HR C/W 12/11  
4A INSP C/W 9/2009  
1C/72MTH INSP C/W 9/2009

**Exterior 09/2009**

WHITE TOP, GRAY BOTTOM W/ GREEN & GOLD STRIPING.

**Interior 2004**

TEN PLACE FIREBLOCKED INTERIOR. FWD DBL CLUB, AFT CONF GROUP OPP SINGLE SEAT, 10TH SEAT AVAILABLE FOR AFT CABIN. LT TAN LEATHER SEATS, MEDIUM TAN CARPET W/ PATTERNED CENTER DESIGN. FWD GALLEY W/TIA COFFEE MAKER, TIA WARMING OVEN, TIA MICROWAVE. ENTERTAINMENT W/AIRSHOW GENESYS, 2-LCD MONITORS, DVD/CD. AFT LAV EXTERNALLY SERVICEABLE. JUMPSEAT & FWD FLIGHT ATTENDANT SEAT. SEATS REFURBISHED 3/06.

**Weights**

MTOGW: 42,200      RAMP: 42,400      ZFW: 29,700      LANDING: 39,300  
BOW: 23,190      EMPTY:      FUEL WT: 16,856      FUEL CAP: 2,497



# Global Jet Sales

Corporate Trading, Inc.

111 Second Ave. NE, Suite 103  
St. Petersburg, FL 33701  
727.864.9443 ~ Fax 727.864.9448

Additional Offices in:  
Redding, CA  
Warrenton, VA

[www.JetSearch.com](http://www.JetSearch.com) ~ [sales@JetSearch.com](mailto:sales@JetSearch.com)

## Exterior



## Cockpit



# Global Jet Sales

Corporate Trading, Inc.

111 Second Ave. NE, Suite 103  
St. Petersburg, FL 33701  
727.864.9443 ~ Fax 727.864.9448

Additional Offices in:  
Redding, CA  
Warrenton, VA

[www.JetSearch.com](http://www.JetSearch.com) ~ [sales@JetSearch.com](mailto:sales@JetSearch.com)

**Interior  
Fwd**



**Interior  
Aft**



# Global Jet Sales

Corporate Trading, Inc.

111 Second Ave. NE, Suite 103  
St. Petersburg, FL 33701  
727.864.9443 ~ Fax 727.864.9448

Additional Offices in:  
Redding, CA  
Warrenton, VA

[www.JetSearch.com](http://www.JetSearch.com) ~ [sales@JetSearch.com](mailto:sales@JetSearch.com)

## Fwd Club Seating





## ESTIMATED VARIABLE COSTS - Per Hour

### Falcon 2000EX

Fuel (1)	\$1,974.32
Fuel Additives	
Lubricants	
Maintenance Labor (2)	196.23
Parts Airframe/Eng/Avion (3)	213.19
Engine Restoration (4)	412.53
Thrust Reverser Allowance	
Propeller Allowance	
APU Allowance	61.63
Major Periodic Maintenance	
Misc Exp. - Landing/Parking	43.30
- Crew Expenses	268.65
- Supplies/Catering	141.75
- Carbon Offset (5)	
- Other	
Fractional Fuel Surcharge Cost/Hour + Tax	
Fractional Cost/Hour + Tax	
<b>Total Variable Cost/Hour</b>	<b>\$3,311.60</b>

**Cost per Nautical Mile** \$7.81

Average Speed-Kts. (6) 600-nm trip 424.00

Cost data in this report is intended to be used as a benchmark

**FOOTNOTES - Size of Operation:** 1 - 2 Aircraft

**Date:** 12/14/2011

**Currency:** \$

**Type of Operation:** Corporate

1. Fuel Cost	6.67
Gallons/Hour Blk Fuel/Flt Time +15%	296
2. Maint. Labor Cost per Hour	93
Maint. Hours/Flight Hours	2.11
3. Incl. Engine Parts Cost	No
Engine Model	PW308C
Aircraft Model Year	2004
4. Overhaul Cost Source	JSSI Prem11
5. CO2 Cost Per Tonne	
6. Block Speed Source	Estimated



---



---

**ANNUAL FIXED COSTS**

---



---

**Falcon 2000EX**

---



---

Crew salaries - Captain (7)	\$130,000
- Co Pilot	85,000
- Flt Attendant	84,000
- Flt Eng/Other	
- Benefits	89,700
Hangar - Typical	55,300
Insurance - Hull (8)	29,700
Single Limit Liability	16,500
<hr/>	
Recurrent Training	56,600
Aircraft Modernization (9)	50,000
Navigation Chart Service	17,802
Refurbishing (10)	78,120
Computer Mx. Program (11)	10,500
Weather Service (12)	700
Other Fixed Costs	
Mgmt Fee/Yr	
<b>Total Fixed Cost/Year</b>	<b>\$703,922</b>

---

Cost data in this report is intended to be used as a benchmark

**FOOTNOTES - Size of Operation: 1 - 2 Aircraft**

**Date:** 12/14/2011

**Currency:** \$

7. Crew Salary Source	10 NBAA
Number of Crew	3
8. Ins Hull Value/Frac Share Cost	16,500,000
Hull Insurance Rate (%)	0.18
9. Modernization	10 Yr Avg
10. Refurbish Labor Hrs/Seat	105
11. Comp. Mx Program Source	Typical
12. Weather Service Source	Typical



**ANNUAL BUDGET**

**Falcon 2000EX**

Utilization - Nt. Miles	175,000
- Hours	413

Variable Cost	1,367,690
Fixed Cost	703,922
<b>Total Cost (No Depreciation)</b>	<b>\$2,071,612</b>
- Per Hour	5,016.00
- Per Nt. Mile	11.84
- Per Seat Nt. Mile	1.48

Total Cost (No Depreciation)	2,071,612
Book Depreciation (13)	1,650,000
<b>Total Cost (Book Dep)</b>	<b>\$3,721,612</b>
- Per Hour	9,011.00
- Per Nt. Mile	21.27
- Per Seat Nt. Mile	2.66

Total Cost (No Depreciation)	2,071,612
Market Depreciation (14)	660,000
<b>Total Cost (Market Dep.)</b>	<b>\$2,731,612</b>
- Per Hour	6,614.00
- Per Nt. Mile	15.61
- Per Seat Nt. Mile	1.95

**Cost data in this report is intended to be used as a benchmark**

**Footnotes - Size of Operation:** 1 - 2 Aircraft

**Date:** 12/14/2011

**Currency:** \$

13. Book Depreciation Rate 10% per yr

14. Market Depreciation Rate 4.00



---



---

## GENERAL COMPARISON

---



---

### Falcon 2000EX

---



---

Cabin-Height (Ft.)	6.20
- Width	7.70
- Length	31.00
Cabin volume (Cu. Ft.)	1,024.00
Cabin Door Height (Ft.)	5.60
- Width	2.60
Baggage -Int. (Cu.Ft.)	131.00
- External	
Typical Crew/Pass Seating	3/8
Weight-Max Take-off (Lbs.)	42,200
- Maximum Landing	39,300
- Basic Operating	23,190
- Usable Fuel	16,660
Payload-Full Fuel (Lbs.)	2,550
- Maximum	6,510
Certified	Yes
IFR Certified	Yes
Price - New (Corporate)/1000	23,550
- Pre Owned Rng/1000	15,500/16,500
- Years Produced	2003 - 2004



---



---

**PERFORMANCE COMPARISON**

---



---

**Falcon 2000EX**

---



---

Range-NBAA IFR Res (N.Mi.)	
Seats Full	3,915
Ferry Range - (Pilot(s) only, no pax)	4,045
Range-30 Min. Res (N.Mi.)	
Seats Full	
Ferry Range - (Pilot(s) only, no pax)	
Balanced Field Length (Ft.)	5,585
Landing Field Length - FAR 91	2,600
Landing Field Length - FAR 121	4,333
Landing Field Length - FAR 135	3,250
Rate Of Climb (Ft/Min)	
- One Engine Out	490
Cruise Speed-Max (KTAS)	
- Normal	459
- Long Range	442
Stall Speed (IAS)	84
Ceiling-Service MTOW (Ft.)	
- Certified	47,000
- Service OEI	26,150
- Hover IGE (Helicopter Only)	
- Hover OGE (Helicopter Only)	

# EXTERIOR

Scale = 1:200

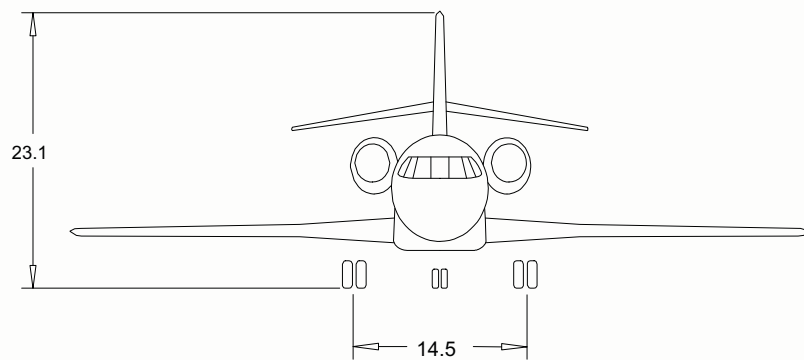
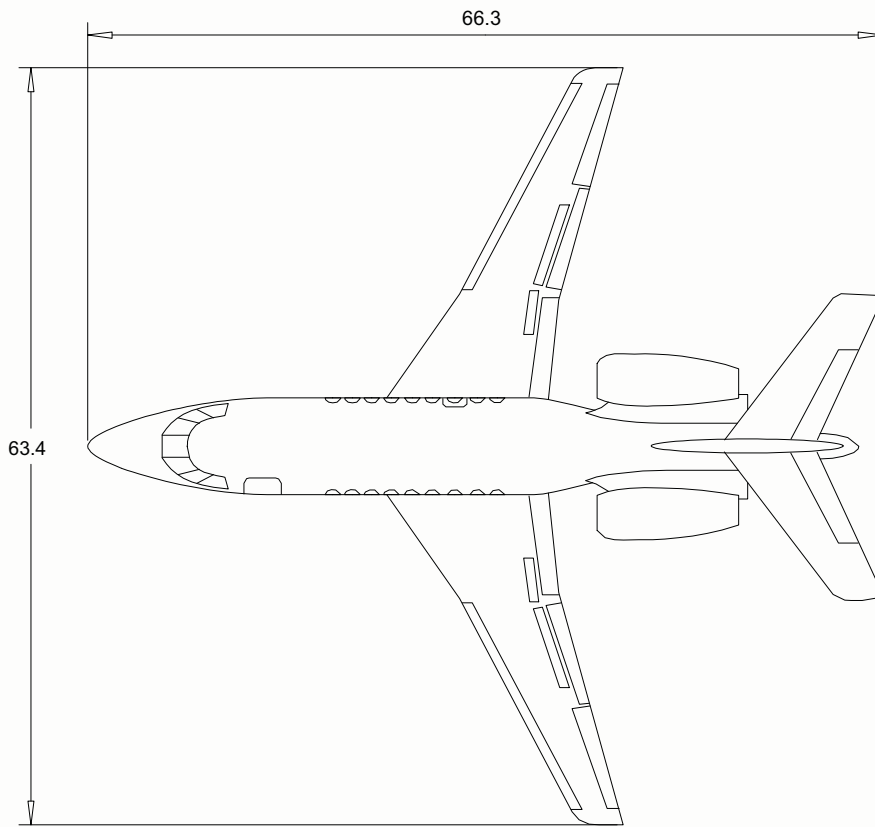
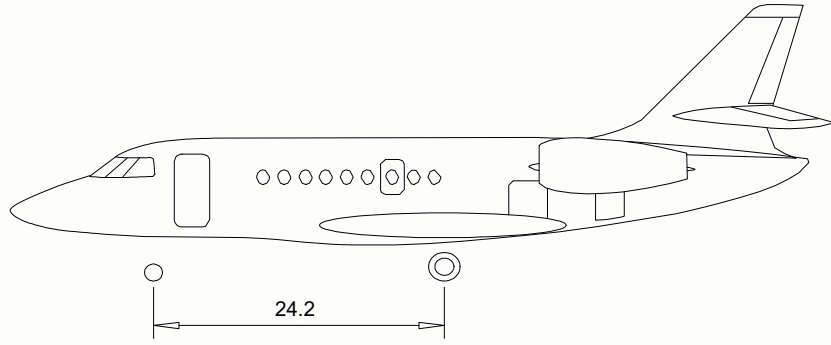

Orleans, Massachusetts (508)255-5975

© 2006 Conklin & de Decker Associates, Inc.

# INTERIOR

Orleans, Massachusetts (508)255-5975

© 2006 Conklin & de Decker Associates, Inc.

Scale = 1:40

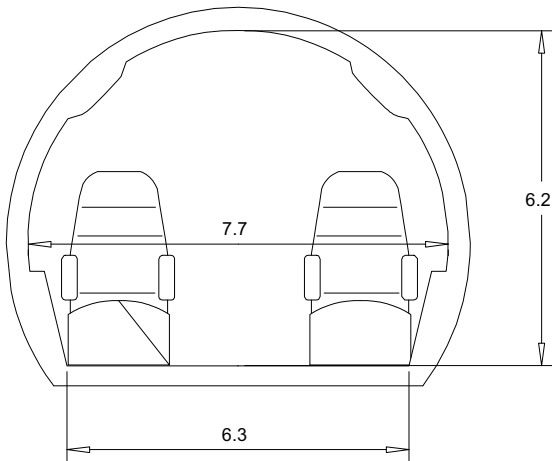

Falcon 2000EX

Scale = 1:60

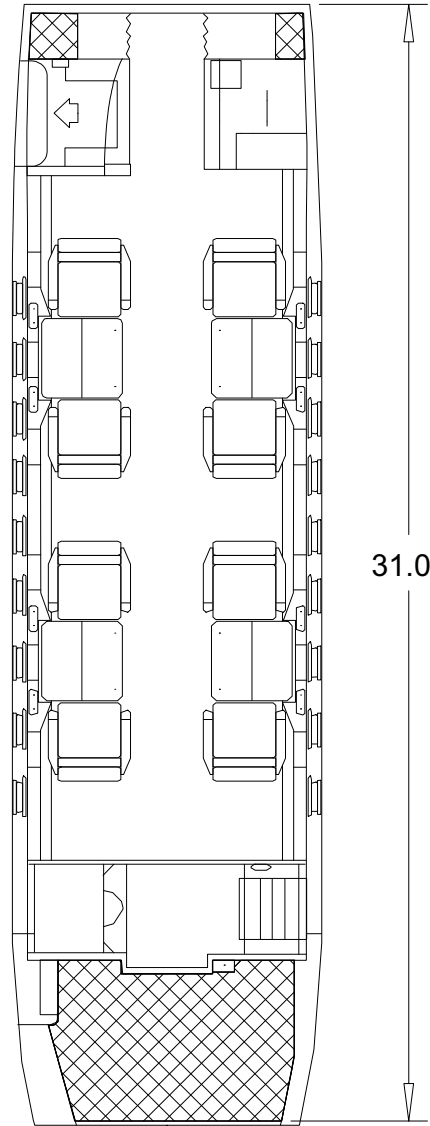

 - Baggage

All dimensions are measured in Feet unless otherwise specified.



## **Falcon 2000EX**

The Falcon 2000EX shares the 900's wing and forward fuselage. It is a twin-engine transcontinental business jet with a cabin 7 feet shorter than the Falcon 900.

The Falcon 2000EX was announced in 2000. It has more fuel capacity the Falcon 2000, Pratt and Whitney 308C power plants, and 700 nautical miles longer range.

It received certification in 2003 and was in production until 2005, when it was replaced by the Falcon 2000EX EASy.